

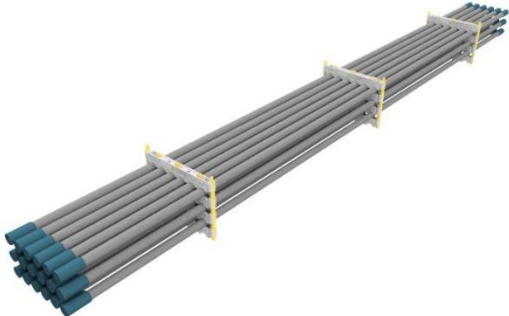
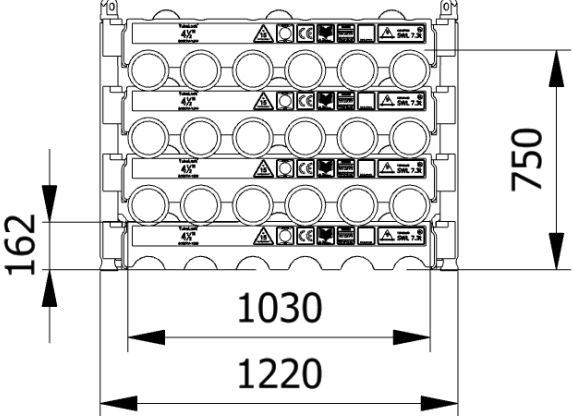

Data sheet 0450TU-1200-3-E	
SWL	7.3 t
Pipe OD	4-1/2"
Maximum weight per pipe	392 kg
Pipe capacity per system	18
M20 Bolt length	200mm
Lifting pole	LP - E
H-Profile	0450-1200
TL weight per system	239 kg
CODES AND STANDARDS <ul style="list-style-type: none"> DNVGL-ST-0378 NORSOK R-002 LOLER 1998 Lifting operation and lifting equipment regulations ILO Conversation No. 152 CE declaration of conformity Machinery Directive: MD2006/42/EC 	
TEST <ul style="list-style-type: none"> Load Test 2X SWL on 20% per batch NDT 100% of Primary per batch before and after test 5 yearly load test 	
	
	
H-Profile 	Lifting Pole 

Stacking

Sketch	Systems Stacked	Height (mm)	Joints	Supported	Truck	Boat	Rig	Yard
A	1	750	18		X	X	X	X
B	2	1440	36		X	X	X	X
C	3	2130	54		(X)		X	X
D	4	2816	72	X			X	X
E	5	3505	90	X			X	X

(x): Depending on Truck set-up and regulation

All sketch dimensions in mm

**SINGLE SYSTEM
(18 JOINTS)**

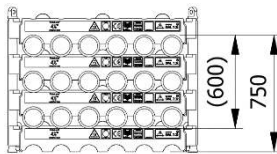

A

**2 SYSTEMS STACKED
(36 JOINTS)**

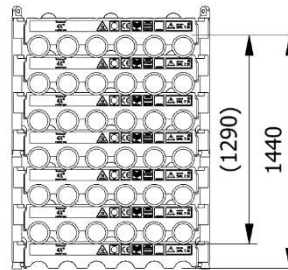

B

**3 SYSTEMS STACKED
(54 JOINTS)**

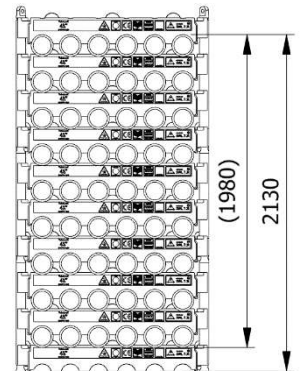

C

**5 SYSTEMS STACKED
(90 JOINTS)**

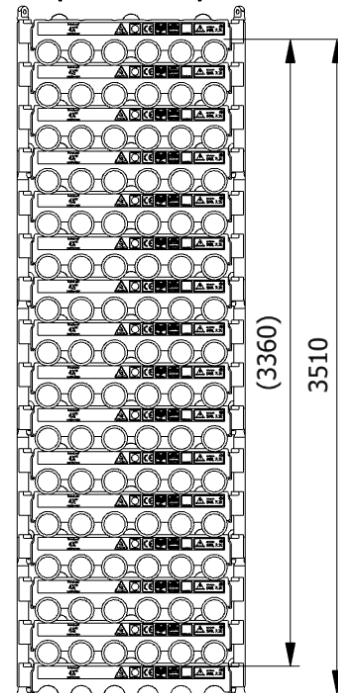

E

**4 SYSTEMS STACKED
(72 JOINTS)**

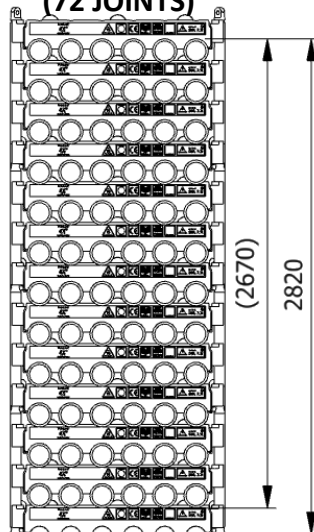

D

Spacing							
Status	w (width) n (number of rows)	S _w (system width)	k(constant)	y(info)	p(info)	T _w (total width)	f(constant)
Storages	$w = S_w + k \cdot (n - 1)$	1000	1110	0	110	$T_w = w + 2f$	110
Running on rig	$w = S_w + k \cdot (n - 1)$	1000	1150	40	150	$T_w = w + 2f$	110

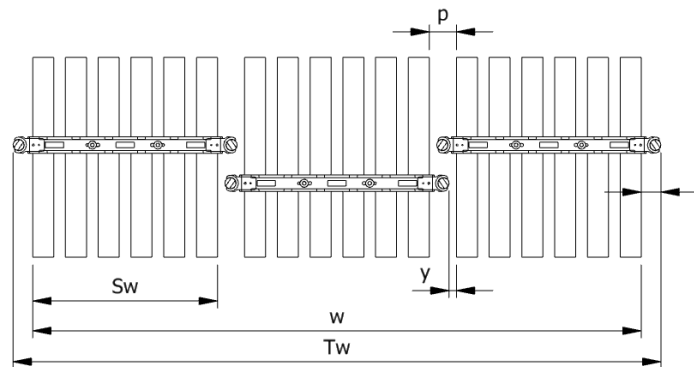

Example: Top view of Systems

Example:
Spacing of 3 systems

$$w = S_w + k \cdot (n - 1) = 1000 + 1110 \cdot (3 - 1) = 3220 \text{ mm}$$

$$T_w = w + 2f = 3220 + 2 \cdot 110 = 3440 \text{ mm}$$

The width “w” for spacing of systems is 3220mm from the first pipe to the last and the total width “T_w” is 3440mm between the 2 outer most Lifting Poles

Footprint

The figure below shows the footprint surface area of a single H-profile.

The footprint is shared between the lowest H-profiles based on the number of frames and the number systems stacked

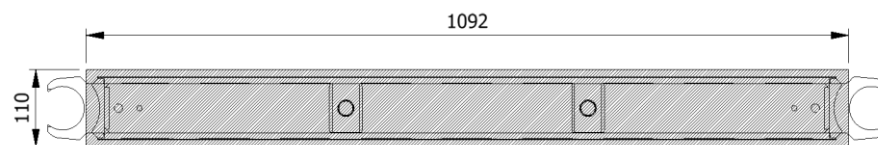

Example: Footprint Surface Area

Maximum Footprint Table (based on 7.3mT SWL)

System Stacked	2 frames	3 frames	4 frames
1	298,4 kN/m ²	202,5 kN/m ²	170,5 kN/m ²
2	596,8 kN/m ²	405 kN/m ²	341 kN/m ²
3	895,2 kN/m ²	607,4 kN/m ²	511,5 kN/m ²
4	1193,6 kN/m ²	809,9 kN/m ²	682 kN/m ²