

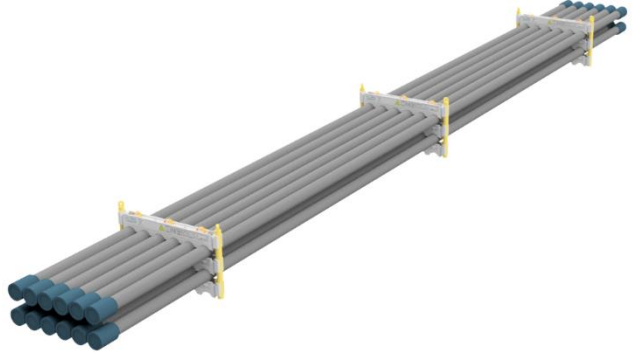
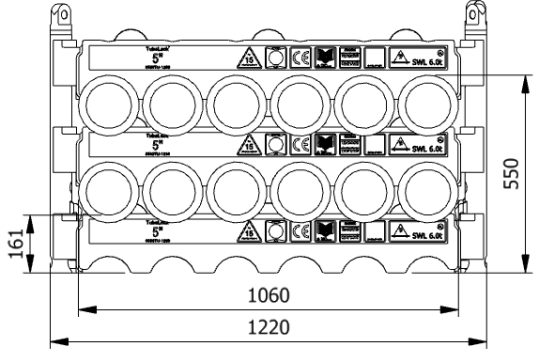

<h2>Data sheet</h2> <h3>0500TU-1200-2-C</h3>	
SWL	7.3 t
Pipe OD	5"
Maximum weight per pipe	593kg
Pipe capacity per system	12
M20 Bolt length	220mm
Lifting pole	LP - C
H-Profile	0500TU-1200
TL weight per system	185 kg
<p>CODES AND STANDARDS</p> <ul style="list-style-type: none"> • DNVGL-ST-0378 • NORSOK R-002 • LOLER 1998 Lifting operation and lifting equipment regulations • ILO Conversation No. 152 • CE declaration of conformity • Machinery Directive: MD2006/42/EC 	
<p>TEST</p> <ul style="list-style-type: none"> • Load Test 2X SWL on 20% per batch • NDT 100% of Primary per batch before and after test • 5 yearly load test 	
	
	
<p>H-Profile</p>	
	
<p>Lifting Pole</p>	
	

Stacking

Sketch (Page 2)	Systems Stacked	Height (mm)	Joints	Supported	Truck	Boat	Rig	Yard
A	1	550	12		X	X	X	X
B	2	1040	24		X	X	X	X
C	3	1520	36		X	X	X	X
D	4	2000	48		(X)		X	X
E	5	2490	60		(X)		X	X
F	6	2970	72	X			X	X
G	7	3460	84	X			X	X
H	8	3940	96	X			X	X

(x): Depending on Truck set-up and regulation

All sketch dimensions in mm

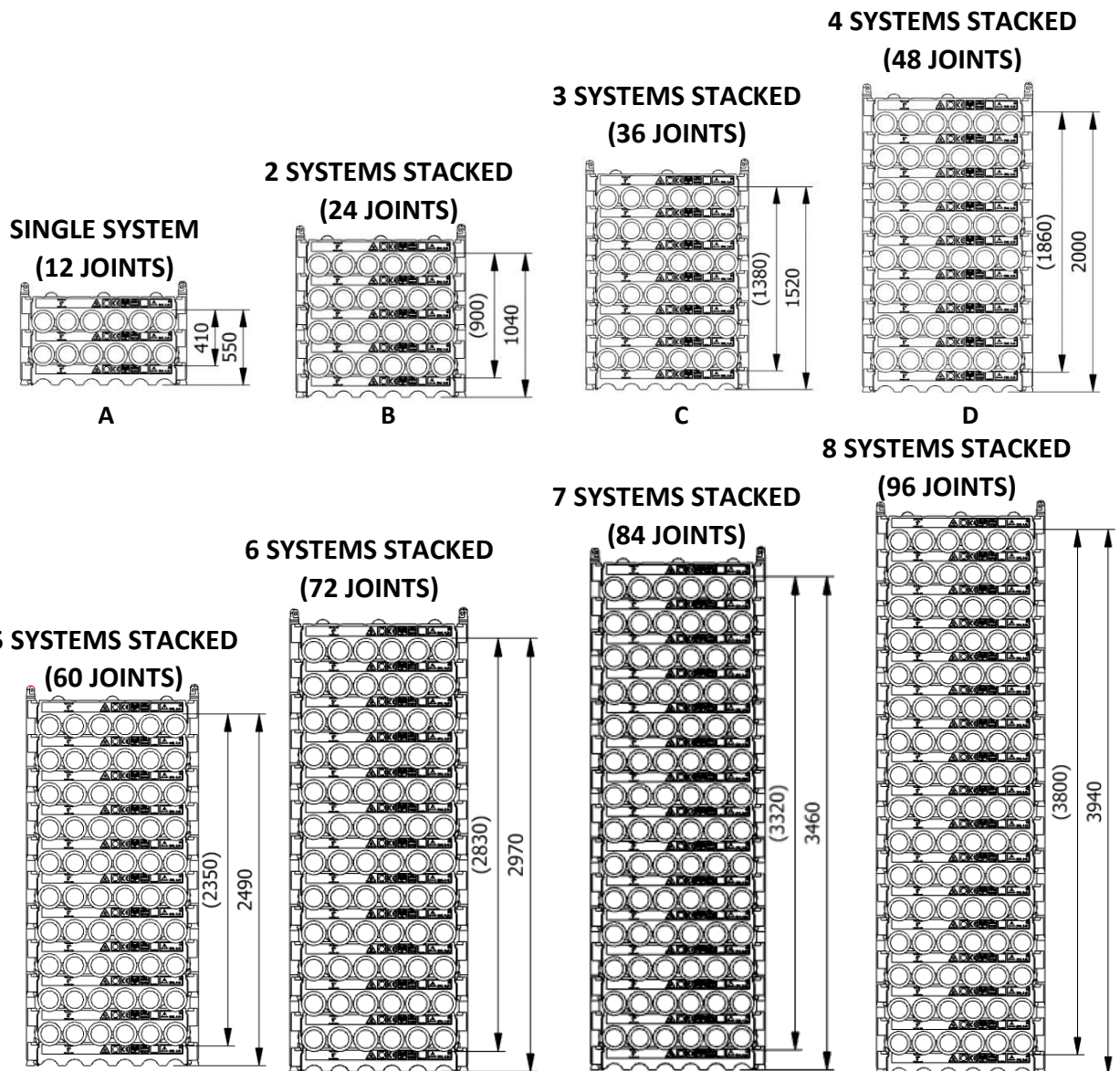

Spacing							
Status	w (width) n (number of rows)	S _w (system width)	k(constant)	y(info)	p(info)	T _w (total width)	f(constant)
Storages	$w = S_w + k \cdot (n - 1)$	1020	1120	0	100	$T_w = w + 2f$	100
Running on rig	$w = S_w + k \cdot (n - 1)$	1020	1160	40	140	$T_w = w + 2f$	100

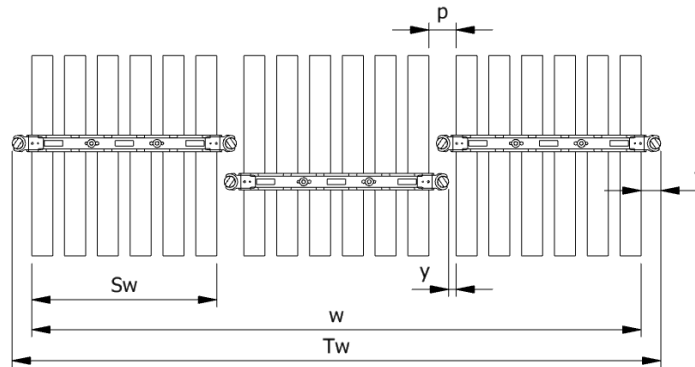

Example: Top view of Systems

Example:
Spacing of 3 systems

$$w = S_w + k \cdot (n - 1) = 1020 + 1120 \cdot (3 - 1) = 3260 \text{ mm}$$

$$T_w = w + 2f = 3260 + 2 \cdot 64 = 3460 \text{ mm}$$

The width “w” for spacing of systems is 3260mm from the first pipe to the last and the total width “T_w” is 3460mm between the 2 outer most Lifting Poles

Footprint

The figure below shows the footprint surface area of a single H-profile.

The footprint is shared between the lowest H-profiles based on the number of frames and the number systems stacked

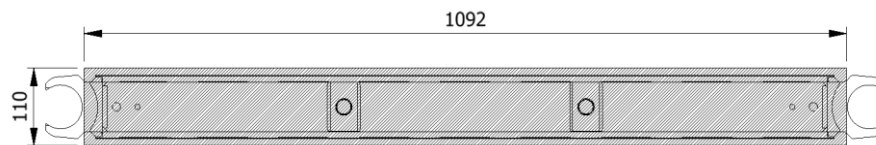

Example: Footprint Surface Area

Maximum Footprint Table (based on 7.3mT SWL)

System Stacked	2 frames	3 frames	4 frames
1	298,4 kN/m ²	202,5 kN/m ²	170,5 kN/m ²
2	596,8 kN/m ²	405 kN/m ²	341 kN/m ²
3	895,2 kN/m ²	607,4 kN/m ²	511,5 kN/m ²
4	1193,6 kN/m ²	809,9 kN/m ²	682 kN/m ²
5	1492 kN/m ²	1012,4 kN/m ²	852,6 kN/m ²
6	1790,4 kN/m ²	1214,9 kN/m ²	1023,1 kN/m ²
7	2088,8 kN/m ²	1417,4 kN/m ²	1193,6 kN/m ²
8	2387,1 kN/m ²	1619,8 kN/m ²	1364,1 kN/m ²