

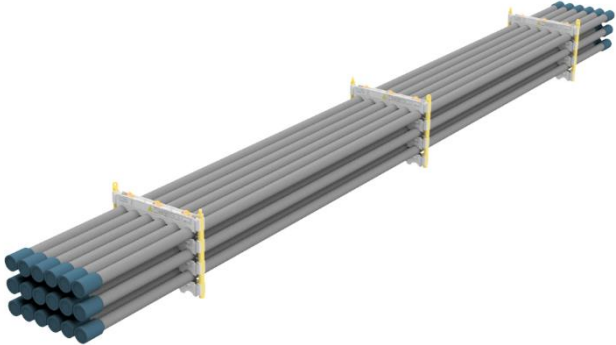
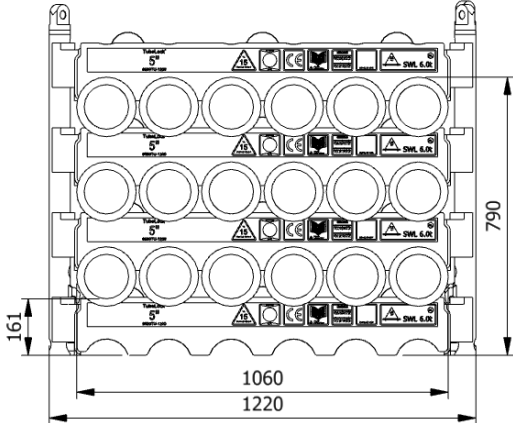

<h2>Data sheet</h2> <h3>0500TU-1200-3-F</h3>	
SWL	7.3 t
Pipe OD	5"
Maximum weight per pipe	588kg
Pipe capacity per system	18
M20 Bolt length	220mm
Lifting pole	LP - F
H-Profile	0500TU-1200
TL weight per system	244 kg
<p><b>CODES AND STANDARDS</b></p> <ul style="list-style-type: none"> <li>• DNVGL-ST-0378</li> <li>• NORSOK R-002</li> <li>• LOLER 1998 Lifting operation and lifting equipment regulations</li> <li>• ILO Conversation No. 152</li> <li>• CE declaration of conformity</li> <li>• Machinery Directive: MD2006/42/EC</li> </ul>	
<p><b>TEST</b></p> <ul style="list-style-type: none"> <li>• Load Test 2X SWL on 20% per batch</li> <li>• NDT 100% of Primary per batch before and after test</li> <li>• 5 yearly load test</li> </ul>	
	
	
<p><b>H-Profile</b></p> 	
<p><b>Lifting Pole</b></p> 	

Stacking								
Sketch	Systems Stacked	Height (mm)	Joints	Supported	Truck	Boat	Rig	Yard
A	1	790	18		x	x	x	x
B	2	1520	36		x	x	x	x
C	3	2250	54		(x)		x	x
D	4	2970	72	x			x	x
E	5	3696	90	x			x	x

(x): Depending on Truck set-up and regulation

All sketch dimensions in mm

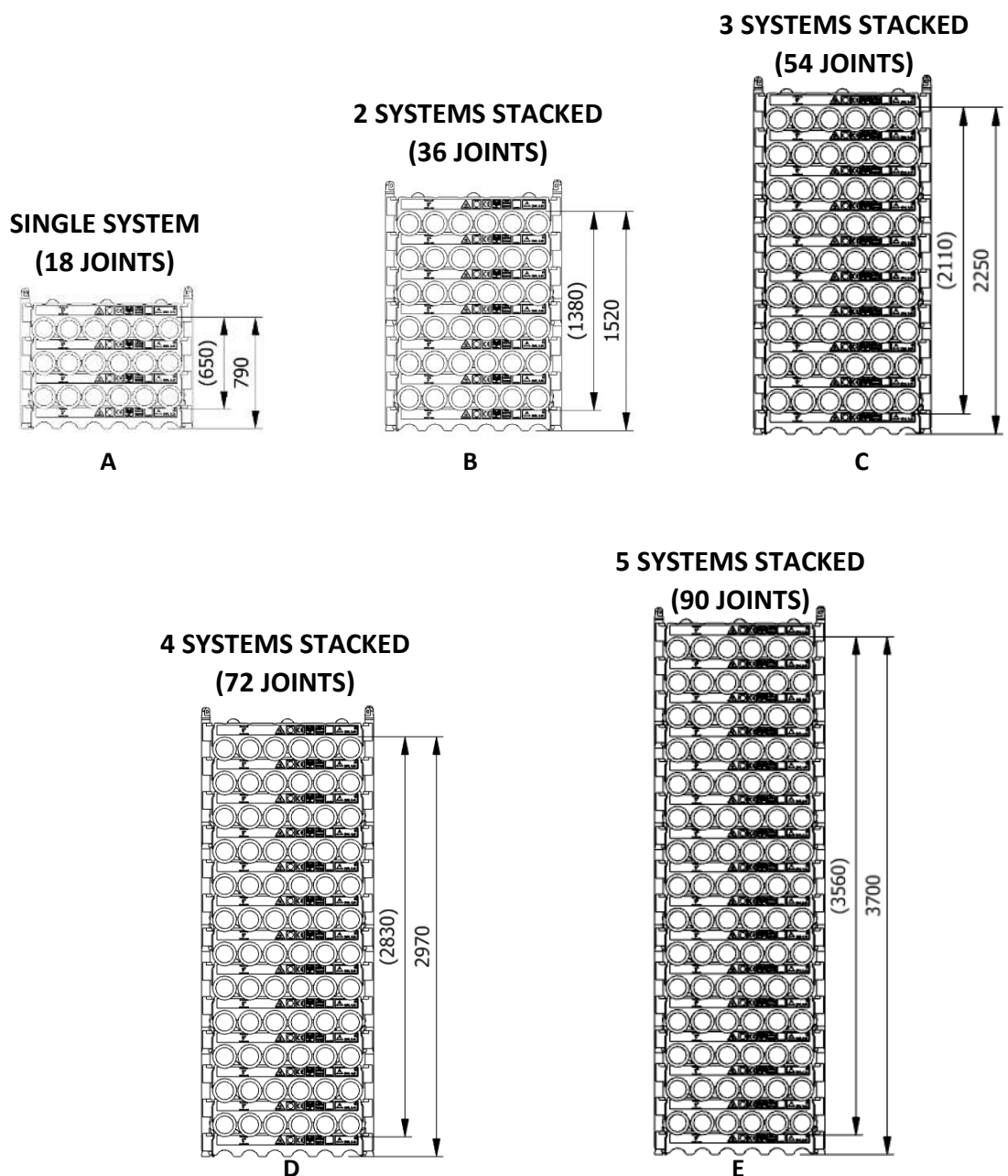

Spacing							
Status	w (width) n (number of rows)	S <sub>w</sub> (system width)	k(constant)	y(info)	p(info)	T <sub>w</sub> (total width)	f(constant)
Storages	$w = S_w + k \cdot (n - 1)$	1020	1120	0	100	$T_w = w + 2f$	100
Running on rig	$w = S_w + k \cdot (n - 1)$	1020	1160	40	140	$T_w = w + 2f$	100

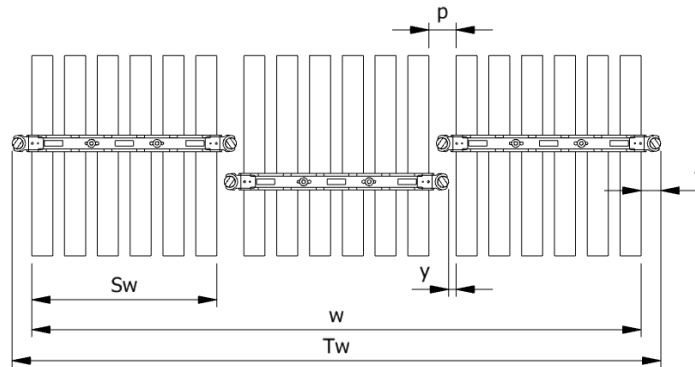

Example: Top view of Systems

Example:  
Spacing of 3 systems

$$w = S_w + k \cdot (n - 1) = 1020 + 1120 \cdot (3 - 1) = 3260 \text{ mm}$$

$$T_w = w + 2f = 3260 + 2 \cdot 64 = 3460 \text{ mm}$$

The width “w” for spacing of systems is 3260mm from the first pipe to the last and the total width “T<sub>w</sub>” is 3460mm between the 2 outer most Lifting Poles

## Footprint

The figure below shows the footprint surface area of a single H-profile.

The footprint is shared between the lowest H-profiles based on the number of frames and the number systems stacked

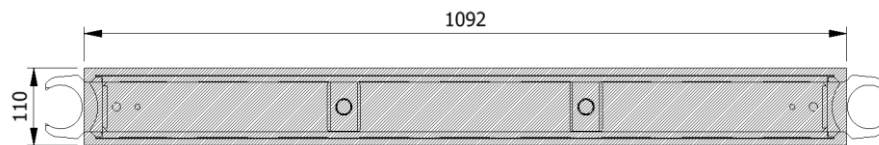

Example: Footprint Surface Area

### Maximum Footprint Table (based on 7.3mT SWL)

System Stacked	2 frames	3 frames	4 frames
1	298,4 kN/m <sup>2</sup>	202,5 kN/m <sup>2</sup>	170,5 kN/m <sup>2</sup>
2	596,8 kN/m <sup>2</sup>	405 kN/m <sup>2</sup>	341 kN/m <sup>2</sup>
3	895,2 kN/m <sup>2</sup>	607,4 kN/m <sup>2</sup>	511,5 kN/m <sup>2</sup>
4	1193,6 kN/m <sup>2</sup>	809,2 kN/m <sup>2</sup>	682 kN/m <sup>2</sup>
5	1492 kN/m <sup>2</sup>	1012,4 kN/m <sup>2</sup>	852,6 kN/m <sup>2</sup>