

Datasheet 0658TU-1200-2-D

SWL	7.3 t
Pipe OD	6 5/8"
Maximum weight per pipe	711kg
Pipe capacity per system	10
M20 Bolt length	260mm
Lifting pole	LP - D
H-Profile	0658TU-1200
TL weight per system	192 kg

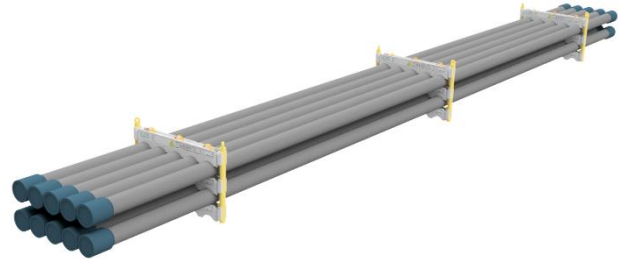

CODES AND STANDARDS

- DNVGL-ST-0378
- NORSOK R-002
- LOLER 1998 Lifting operation and lifting equipment regulations
- ILO Conversation No. 152
- CE declaration of conformity
- Machinery Directive: MD2006/42/EC

TEST

- Load Test 2X SWL on 20% per batch
- NDT 100% of Primary per batch before and after test
- 5 yearly load test

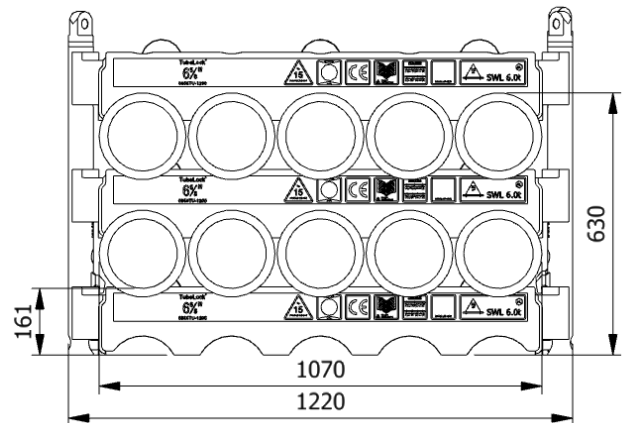

H-Profile



Lifting Pole



Stacking

Sketch (Page 2)	Systems Stacked	Height (mm)	Joints	Supported	Truck	Boat	Rig	Yard
A	1	630	10		x	x	x	x
B	2	1200	20		x	x	x	x
C	3	1770	30		x	x	x	x
D	4	2330	40		(x)		x	x
E	5	2900	50	x			x	x
F	6	3470	60	x			x	x

(x): Depending on Truck set-up and regulation

All sketch dimensions in mm

**SINGLE SYSTEM
(10 JOINTS)**

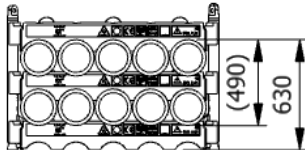

A

**2 SYSTEMS STACKED
(20 JOINTS)**

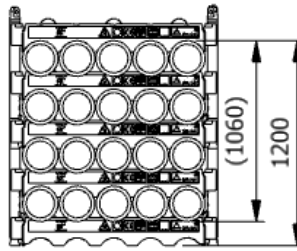

B

**3 SYSTEMS STACKED
(30 JOINTS)**

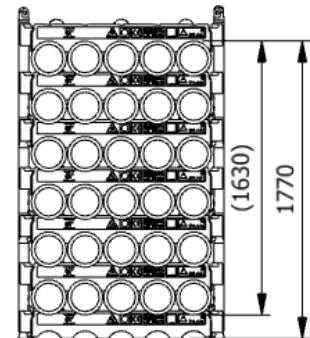

C

**4 SYSTEMS STACKED
(40 JOINTS)**

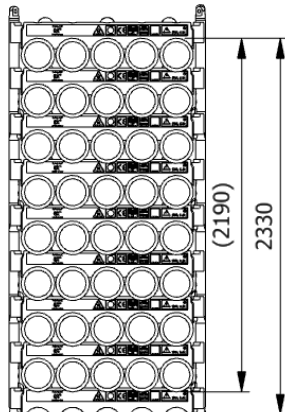

D

**5 SYSTEMS STACKED
(50 JOINTS)**

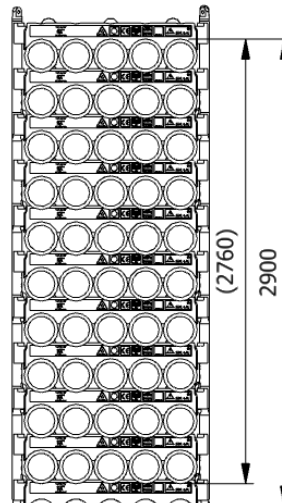

E

**6 SYSTEMS STACKED
(60 JOINTS)**

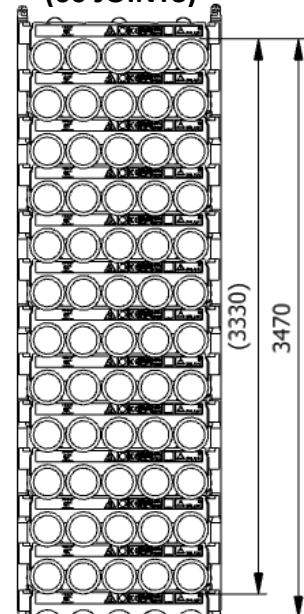

F

Spacing

Status	w (width) n (number of rows)	S_w (system width)	k (constant)	y (info)	p (info)	T_w (total width)	f (constant)
Storages	$w = S_w + k \cdot (n - 1)$	1030	1125	0	95	$T_w = w + 2f$	95
Running on rig	$w = S_w + k \cdot (n - 1)$	1030	1165	40	135	$T_w = w + 2f$	95

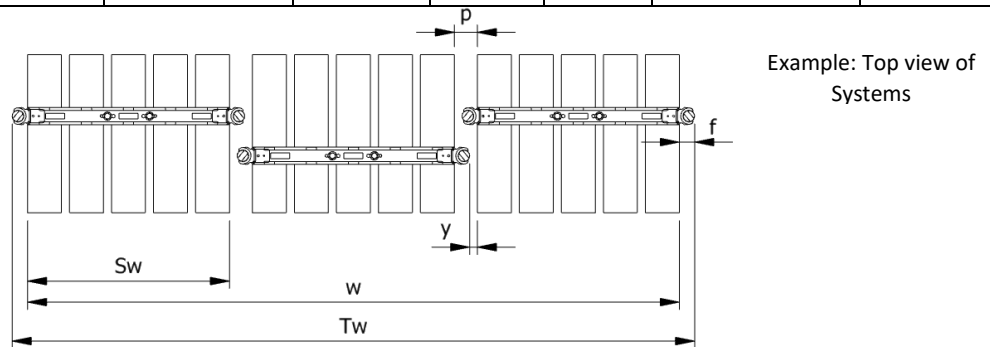

Example:
Spacing of 3 systems

$$w = S_w + k \cdot (n - 1) = 1030 + 1125 \cdot (3 - 1) = 3280 \text{ mm}$$

$$T_w = w + 2f = 3280 + 2 \cdot 95 = 3470 \text{ mm}$$

The width “w” for spacing of systems is 3280mm from the first pipe to the last and the total width “ T_w ” is 3470mm between the 2 outer most Lifting Poles

Footprint

The figure below shows the footprint surface area of a single H-profile.

The footprint is shared between the lowest H-profiles based on the number of frames and the number systems stacked

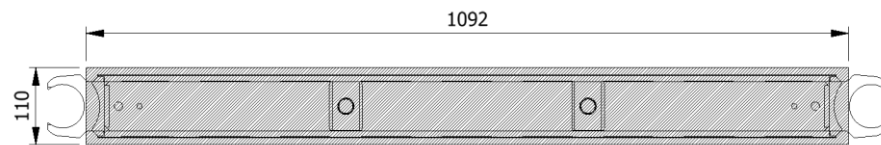

Example: Footprint Surface Area

Maximum Footprint Table (based on 7.3mT SWL)

System Stacked	2 frames	3 frames	4 frames
1	298,4 kN/m ²	202,5 kN/m ²	170,5 kN/m ²
2	596,8 kN/m ²	405 kN/m ²	341 kN/m ²
3	895,2 kN/m ²	607,4 kN/m ²	511,5 kN/m ²
4	1193,6 kN/m ²	809,9 kN/m ²	682 kN/m ²
5	1492 kN/m ²	1012,4 kN/m ²	852,6 kN/m ²
6	1790,4 kN/m ²	1214,9 kN/m ²	1023,1 kN/m ²