

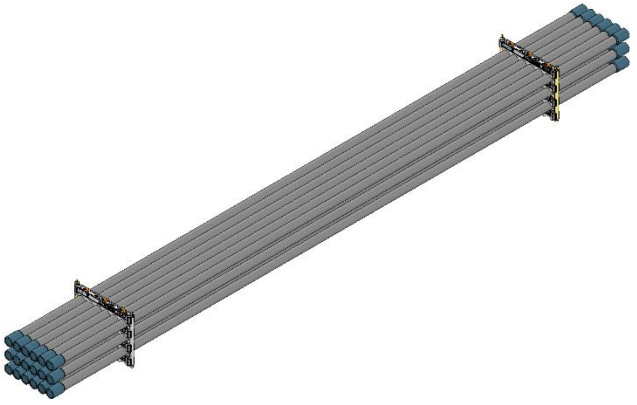
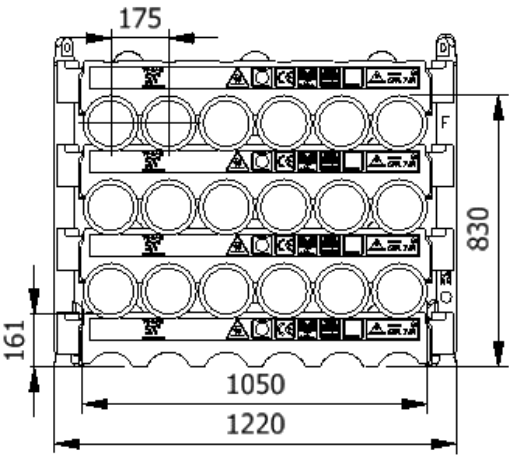

<h2>Data sheet</h2> <h3>0550TU-1200-3-F</h3>		
SWL	7.3 t	
Pipe OD	5-1/2"	
Maximum weight per pipe	397kg	
Pipe capacity per system	18	
M20 Bolt length	220mm	
Lifting pole	LP - F	
H-Profile	0550TU-1200	
TL weight per system	146 kg	
<p>CODES AND STANDARDS</p> <ul style="list-style-type: none"> • DNVGL-ST-0378 • NORSOK R-002 • LOLER 1998 Lifting operation and lifting equipment regulations • ILO Conversation No. 152 • CE declaration of conformity • Machinery Directive: MD2006/42/EC 		
<p>TEST</p> <ul style="list-style-type: none"> • Load Test 2X SWL on 5% per batch • NDT 100% of Primary per batch before and after test 		
<p>H-Profile</p> 		<p>Lifting Pole</p> 

Stacking

Layer	Systems Stacked	Height (mm)	Joints	Supported	Truck	Boat	Rig	Yard
1	1	830	18		x	x	x	x
2	2	1590	36		x	x	x	x
3	3	2350	54		(x)		x	x
4	4	3120	72	x			x	x
5	5	3880	90	x			x	x

(x): Depending on Truck set-up and regulation

All sketch dimensions in mm

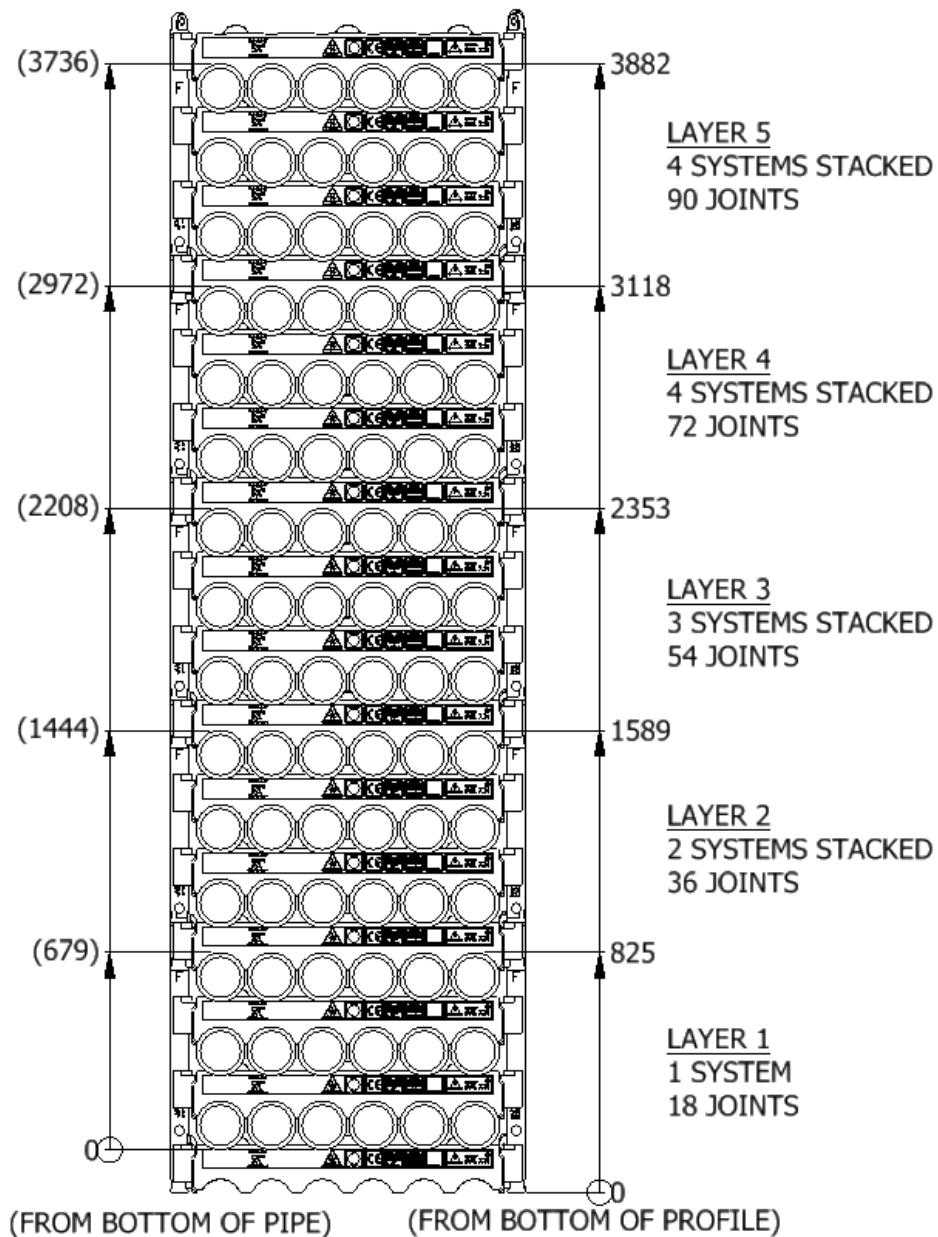

Spacing							
Status	w (width) n (number of rows)	S _w (system width)	k(constant)	y(info)	p(info)	T _w (total width)	f(constant)
Storages	$w = S_w + k \cdot (n - 1)$	1015	1116	0	102	$T_w = w + 2f$	101
Running on rig	$w = S_w + k \cdot (n - 1)$	1015	1157	40	142	$T_w = w + 2f$	101

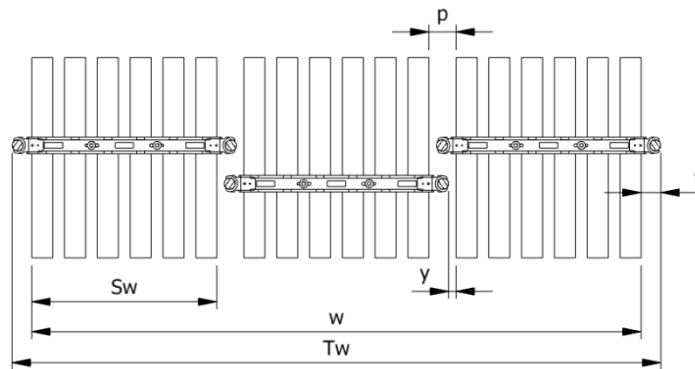

Example: Top view of Systems

Example:
Spacing of 3 systems

$$w = S_w + k \cdot (n - 1) = 1015 + 1116 \cdot (3 - 1) = 3247 \text{ mm}$$

$$T_w = w + 2f = 3247 + 2 \cdot 101 = 3449 \text{ mm}$$

The width “w” is the distance between the 2 outer most pipes
The total width “T_w” is between the 2 outer most Lifting Poles

Footprint

The figure below shows the footprint surface area of a TubeLock® system.
Each additional system stacked, will be added to the total footprint

	System Stacked	Footprint
	1	5 kN/m ²
	2	10 kN/m ²
	3	15 kN/m ²
	4	20 kN/m ²
	5	25 kN/m ²