



<h2>Data sheet</h2> <h3>0578TU-1200-2-D</h3>	
SWL	7.3 t
Pipe OD	5-7/8"
Maximum weight per pipe	711kg
Pipe capacity per system	10
M20 Bolt length	240mm
Lifting pole	LP - D
H-Profile	0578TU-1200
TL weight per system	191 kg
<p>CODES AND STANDARDS</p> <ul style="list-style-type: none"> • DNVGL-ST-0378 • NORSOK R-002 • LOLER 1998 Lifting operation and lifting equipment regulations • ILO Conversation No. 152 • CE declaration of conformity • Machinery Directive: MD2006/42/EC 	
<p>TEST</p> <ul style="list-style-type: none"> • Load Test 2X SWL on 5% per batch • NDT 100% of Primary per batch before and after test 	
<p>H-Profile</p> 	<p>Lifting Pole</p> 
	
	

Stacking

Layer	Systems Stacked	Height (mm)	Joints	Supported	Truck	Boat	Rig	Yard
1	1	590	10		x	x	x	x
2	2	1110	20		x	x	x	x
3	3	1640	30		x	x	x	x
4	4	2170	40		(x)		x	x
5	5	2700	50	x			x	x
6	6	3230	60	x			x	x

(x): Depending on Truck set-up and regulation

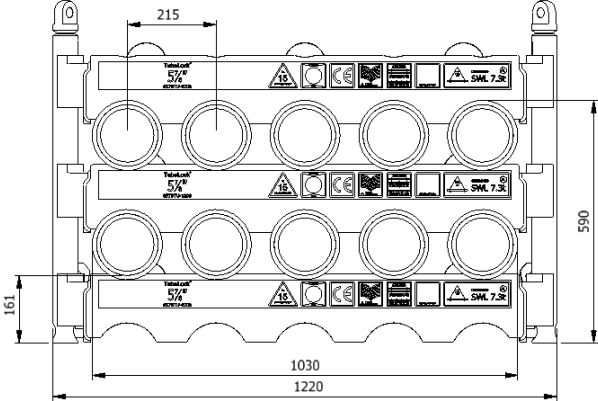
All sketch dimensions in mm

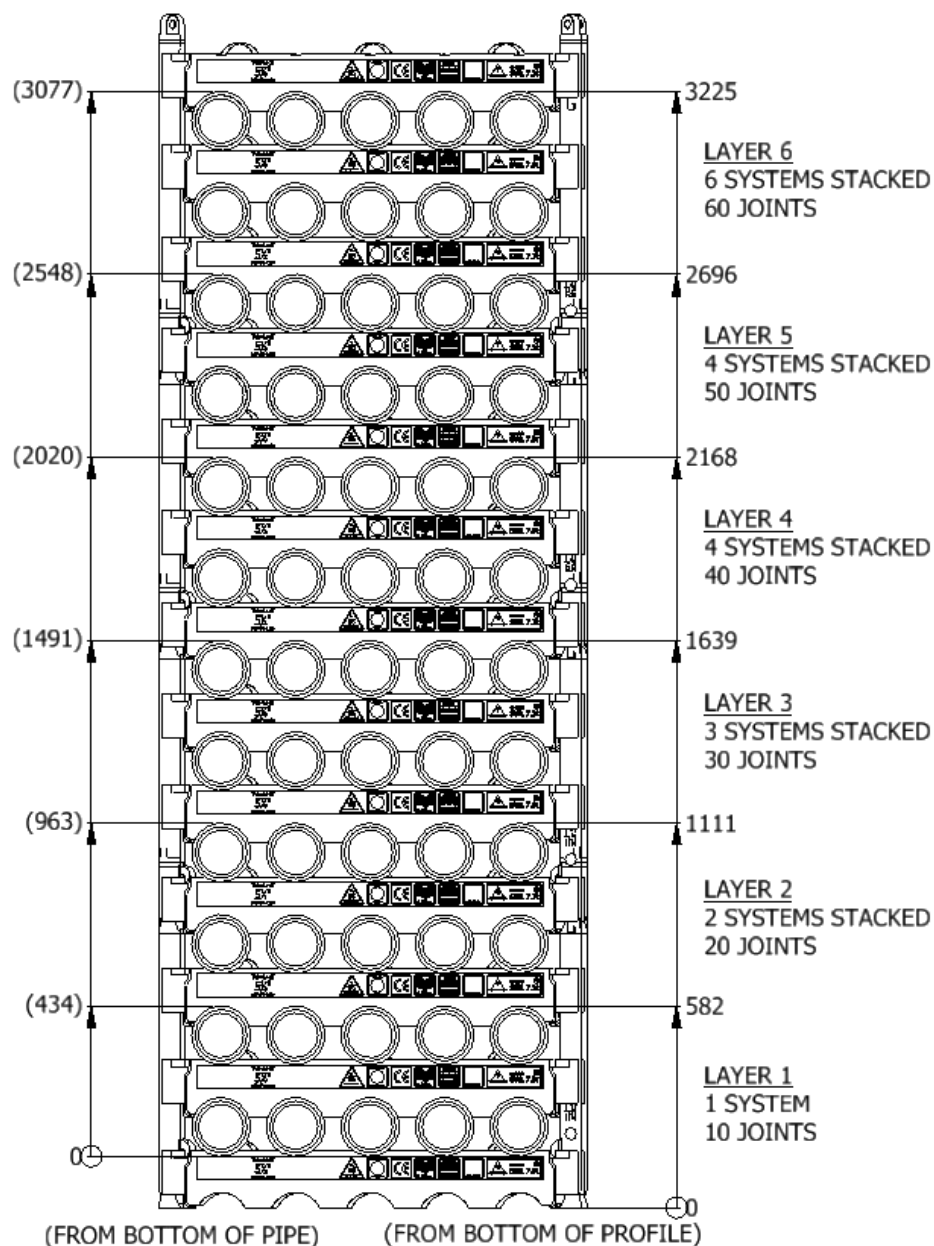

Spacing							
Status	w (width) n (number of rows)	S_w (system width)	k (constant)	y (info)	p (info)	T_w (total width)	f (constant)
Storages	$w = S_w + k \cdot (n - 1)$	1010	1110	0	100	$T_w = w + 2f$	100
Running on rig	$w = S_w + k \cdot (n - 1)$	1010	1150	40	140	$T_w = w + 2f$	100

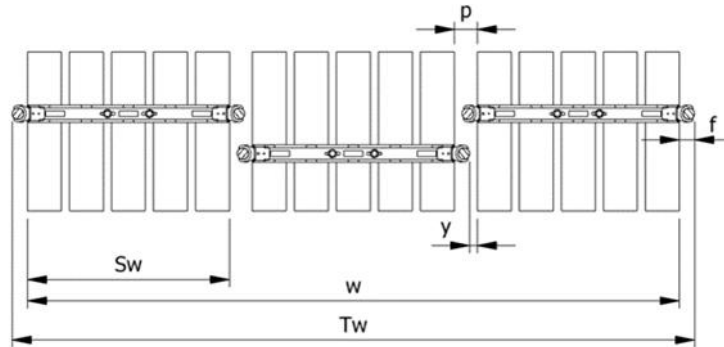

Topview of systems

Example:
Spacing of 3 systems

$$w = S_w + k \cdot (n - 1) = 1010 + 1110 \cdot (3 - 1) = 3230\text{mm}$$

$$T_w = w + 2f = 3230 + 2 \cdot 100 = 3430\text{mm}$$

The width “w” is the distance between the 2 outer most pipes
The total width “ T_w ” is between the 2 outer most Lifting Poles

Footprint

The figure below shows the footprint surface area of a TubeLock® system.
Each additional system stacked, will be added to the total footprint

		System Stacked	Footprint
		1	5 kN/m ²
2	10 kN/m ²		
3	15 kN/m ²		
4	20 kN/m ²		
5	25 kN/m ²		
6	30 kN/m ²		