

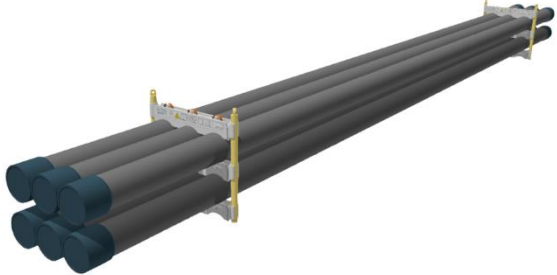
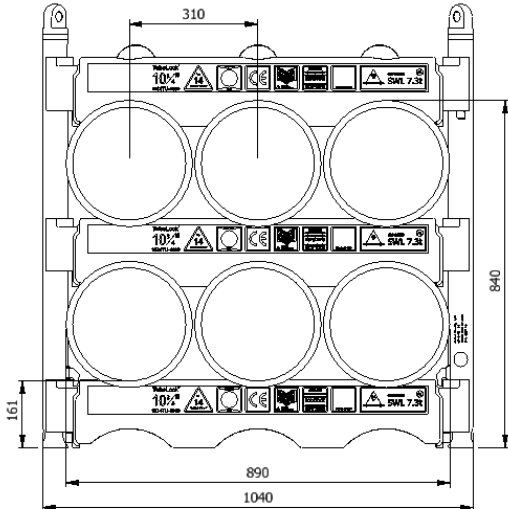

<h2>Data sheet</h2> <h3>1034TU-1000-2-G</h3>	
SWL	7,3 t
Pipe OD	10 3/4"
Maximum weight per pipe	1195 kg
Pipe capacity per system	6
M20 Bolt length	360mm
Lifting pole	LP - G
H-Profile	1034TU-1000
TL weight per system	131 kg
<p>CODES AND STANDARDS</p> <ul style="list-style-type: none"> • DNVGL-ST-0378 • NORSOK R-002 • LOLER 1998 Lifting operation and lifting equipment regulations • ILO Conversation No. 152 • CE declaration of conformity • Machinery Directive: MD2006/42/EC 	
<p>TEST</p> <ul style="list-style-type: none"> • Load Test 2X SWL on 5% per batch • NDT 100% of Primary per batch before and after test 	
	
	
<p>H-Profile</p> 	<p>Lifting Pole</p> 

Stacking

Sketch	Systems Stacked	Height (mm)	Joints	Supported	Truck	Boat	Rig	Yard
A	1	840	6		X	X	X	X
B	2	1610	12		X	X	X	X
C	3	2390	18				X	X
D	4	3170	24	X			X	X
E	5	3940	30	X			X	X

(x): Depending on Truck set-up and regulation

All sketch dimensions in mm

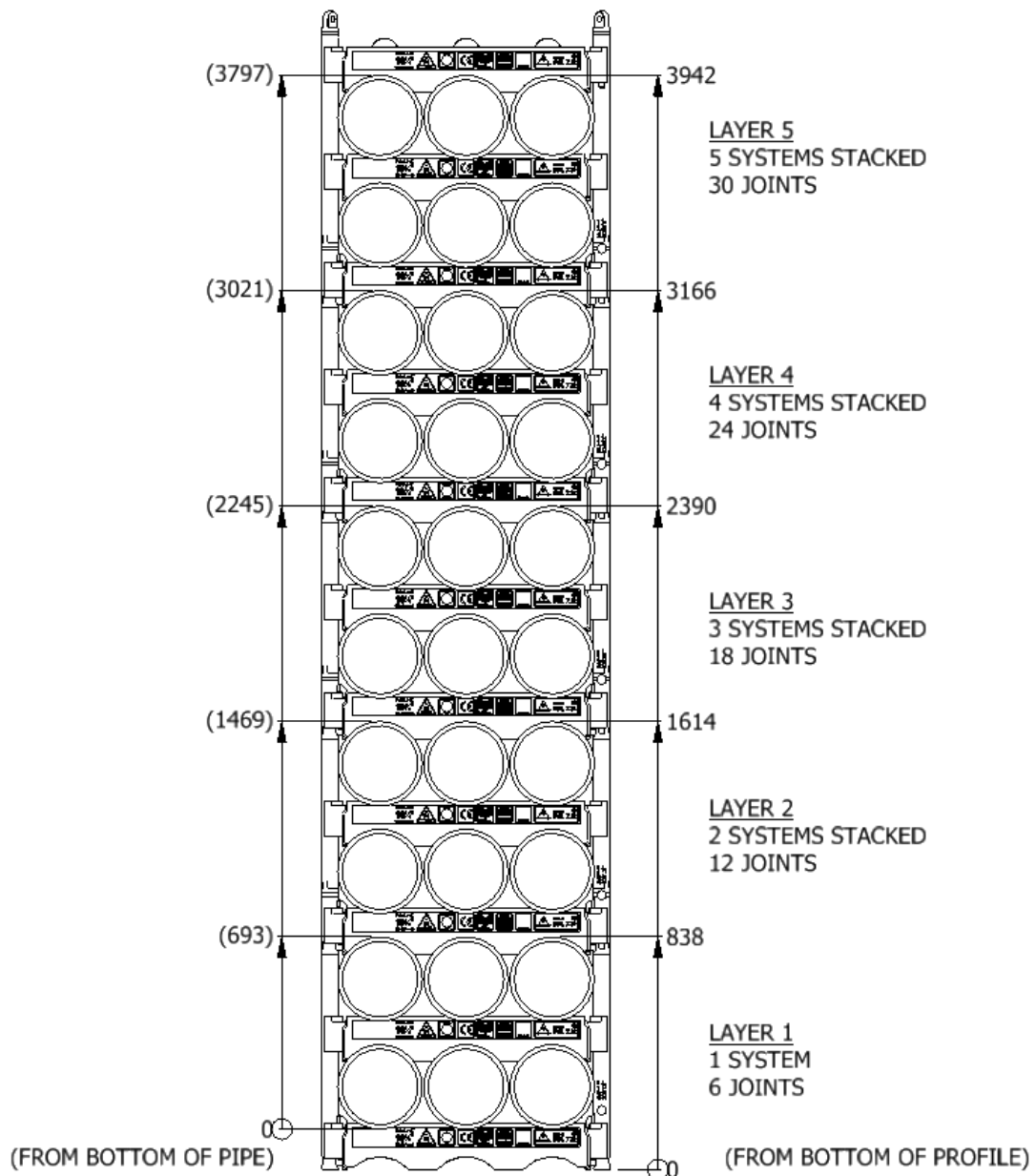

Spacing							
Status	w (width) n (number of rows)	S _w (system width)	k(constant)	y(info)	p(info)	T _w (total width)	f(constant)
Storages	$w = S_w + k \cdot (n - 1)$	890	960	0	70	$T_w = w + 2f$	70
Running on rig	$w = S_w + k \cdot (n - 1)$	890	1000	40	111	$T_w = w + 2f$	70

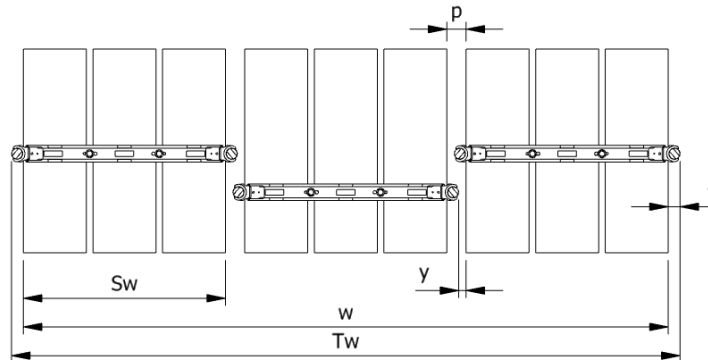

Example: Top view of Systems

Example:
Spacing of 3 systems

$$w = S_w + k \cdot (n - 1) = 890 + 960 \cdot (3 - 1) = 2810\text{mm}$$

$$T_w = w + 2f = 2810 + 2 \cdot 70 = 2950\text{mm}$$

The width "w" is the distance between the 2 outer most pipes
The total width "T_w" is between the 2 outer most Lifting Poles.

Footprint

The figure below shows the footprint surface area of a TubeLock® system.
Each additional system stacked, will be added to the total footprint.

Footprint Surface Area	System Stacked	Footprint
	1	6 kN/m ²
	2	12 kN/m ²
	3	18 kN/m ²
	4	24 kN/m ²
	5	30 kN/m ²