

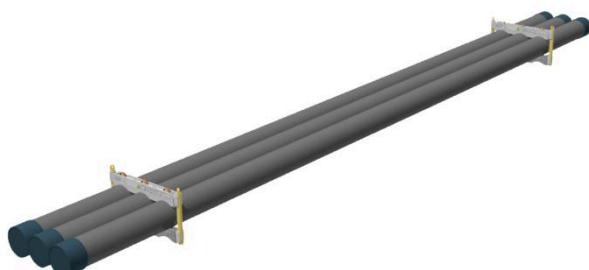
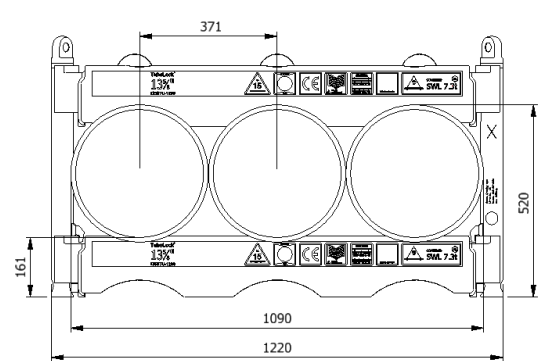

<h2 style="margin: 0;">Datasheet</h2> <h1 style="margin: 0;">1358TU-1200-1-X</h1>	
SWL	7.3 t
Pipe OD	13-5/8"
Maximum weight per pipe	2399 kg
Pipe capacity per system	3
M20 Bolt length	430mm
Lifting pole	LP - X
H-Profile	1358TU-1200
TL weight per system	101 kg
<p>CODES AND STANDARDS</p> <ul style="list-style-type: none"> • DNVGL-ST-0378 • NORSOK R-002 • LOLER 1998 Lifting operation and lifting equipment regulations • ILO Conversation No. 152 • CE declaration of conformity • Machinery Directive: MD2006/42/EC 	
<p>TEST</p> <ul style="list-style-type: none"> • Load Test 2X SWL on 5% per batch • NDT 100% of Primary per batch before and after test 	
	
	
<p>H-Profile</p> 	<p>Lifting Pole</p> 

Stacking

Sketch	Systems Stacked	Height (mm)	Joints	Supported	Truck	Boat	Rig	Yard
A	1	520	3		X	X	X	X
B	2	980	6		X	X	X	X
C	3	1440	9		X	X	X	X
D	4	1900	12		X	X	X	X
E	5	2360	15		(X)		X	X
F	6	2830	18	X			X	X

(X): Depending on Truck set-up and regulation

All sketch dimensions in mm

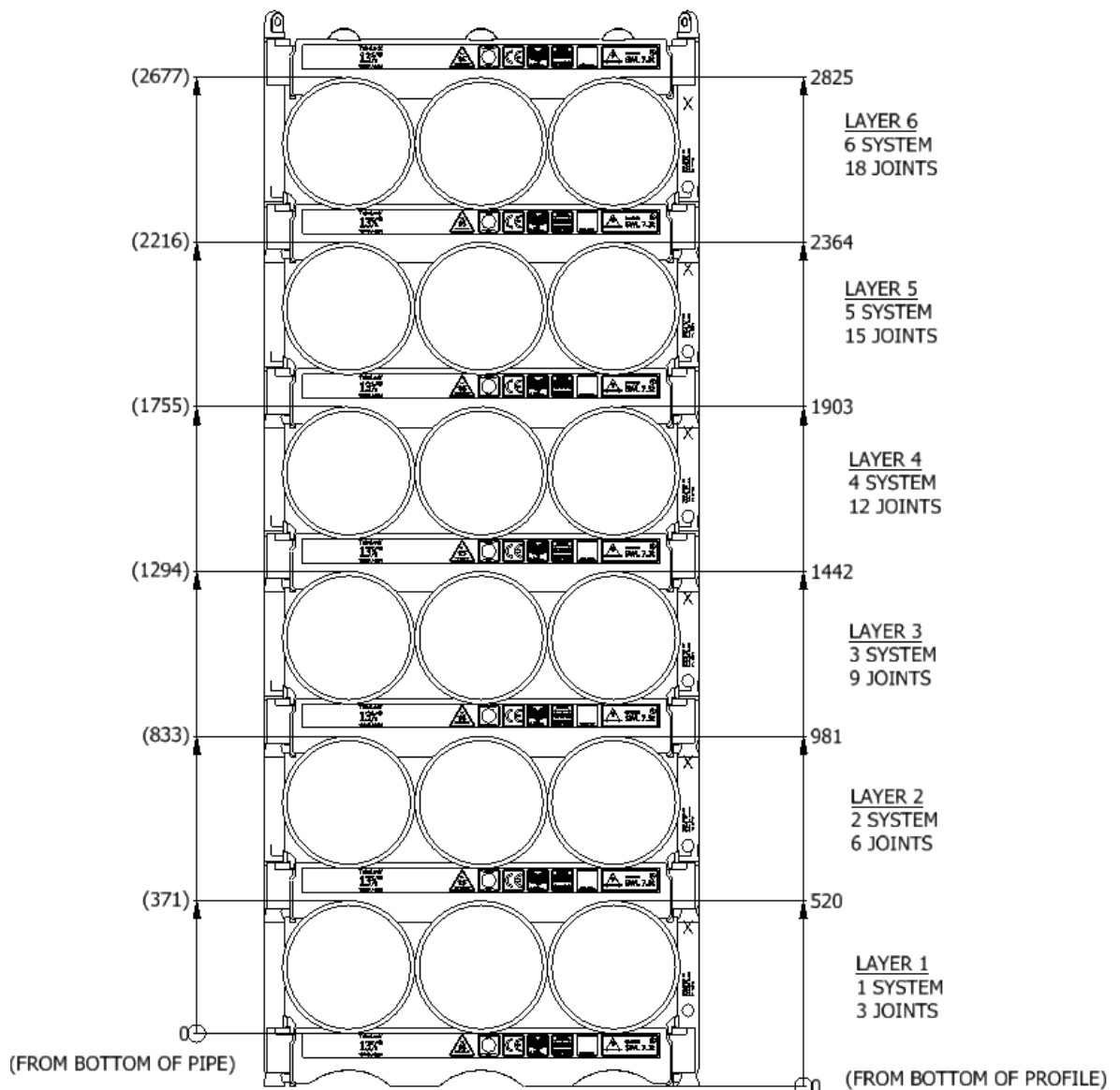

Spacing

Status	w (width) n (number of rows)	S _w (system width)	k(constant)	y(info)	p(info)	T _w (total width)	f(constant)
Storages	$w = S_w + k \cdot (n - 1)$	1090	1154	0	64	$T_w = w + 2f$	64
Running on rig	$w = S_w + k \cdot (n - 1)$	1090	1194	40	104	$T_w = w + 2f$	64

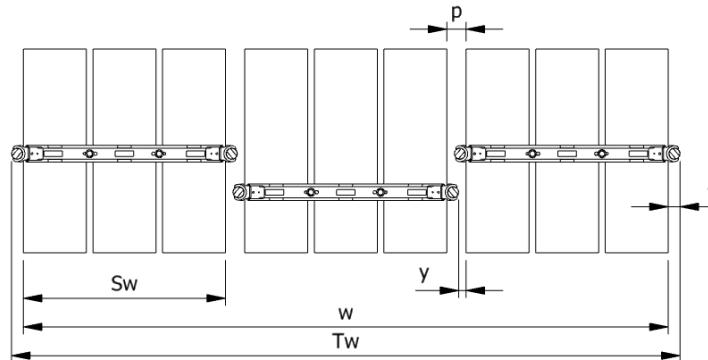

Example: Top view of Systems

Example:
Spacing of 3 systems

$$w = S_w + k \cdot (n - 1) = 1090 + 1154 \cdot (3 - 1) = 3398mm$$

$$T_w = w + 2f = 3526 + 2 \cdot 64 = 3526mm$$

The width "w" is the distance between the 2 outer most pipes
The total width "T_w" is between the 2 outer most Lifting Poles

Footprint

The figure below shows the footprint surface area of a TubeLock® system.

Each additional system stacked, will be added to the total footprint.

Footprint surface area	System Stacked	Footprint
<p>12 m</p> <p>1,2 m</p>	1	5 kN/m ²
	2	10 kN/m ²
	3	15 kN/m ²
	4	20 kN/m ²
	5	25 kN/m ²
	6	30 kN/m ²