

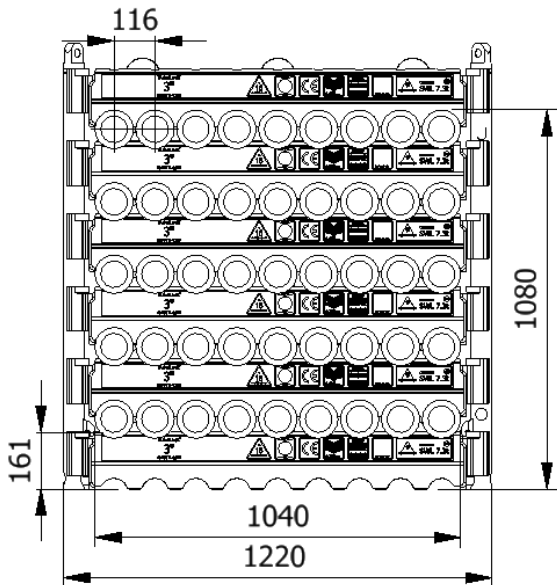

<h2>Data sheet</h2> <h3>0300TU-1200-5-J</h3>	
SWL	7,3 t
Pipe OD	3"
Maximum weight per pipe	154kg
Pipe capacity per system	45
M20 Bolt length	170mm
Lifting pole	LP - J
H-Profile	0300TU-1200
TL weight per system	346 kg
<p>CODES AND STANDARDS</p> <ul style="list-style-type: none"> • DNVGL-ST-0378 • NORSOK R-002 • LOLER 1998 Lifting operation and lifting equipment regulations • ILO Conversation No. 152 • CE declaration of conformity • Machinery Directive: MD2006/42/EC 	
<p>TEST</p> <ul style="list-style-type: none"> • Load Test 2X SWL on 5% per batch • NDT 100% of Primary per batch before and after test 	
	
	
<p>H-Profile</p> 	<p>Lifting Pole</p> 

Stacking

Systems Stacked	Height (mm)	Joints	Supported	Truck	Boat	Rig	Yard
1	1079	45		x	x	x	x
2	2110	90		(x)		x	x
3	3141	135	x			x	x

(x): Depending on Truck set-up and regulation

All sketch dimensions in mm

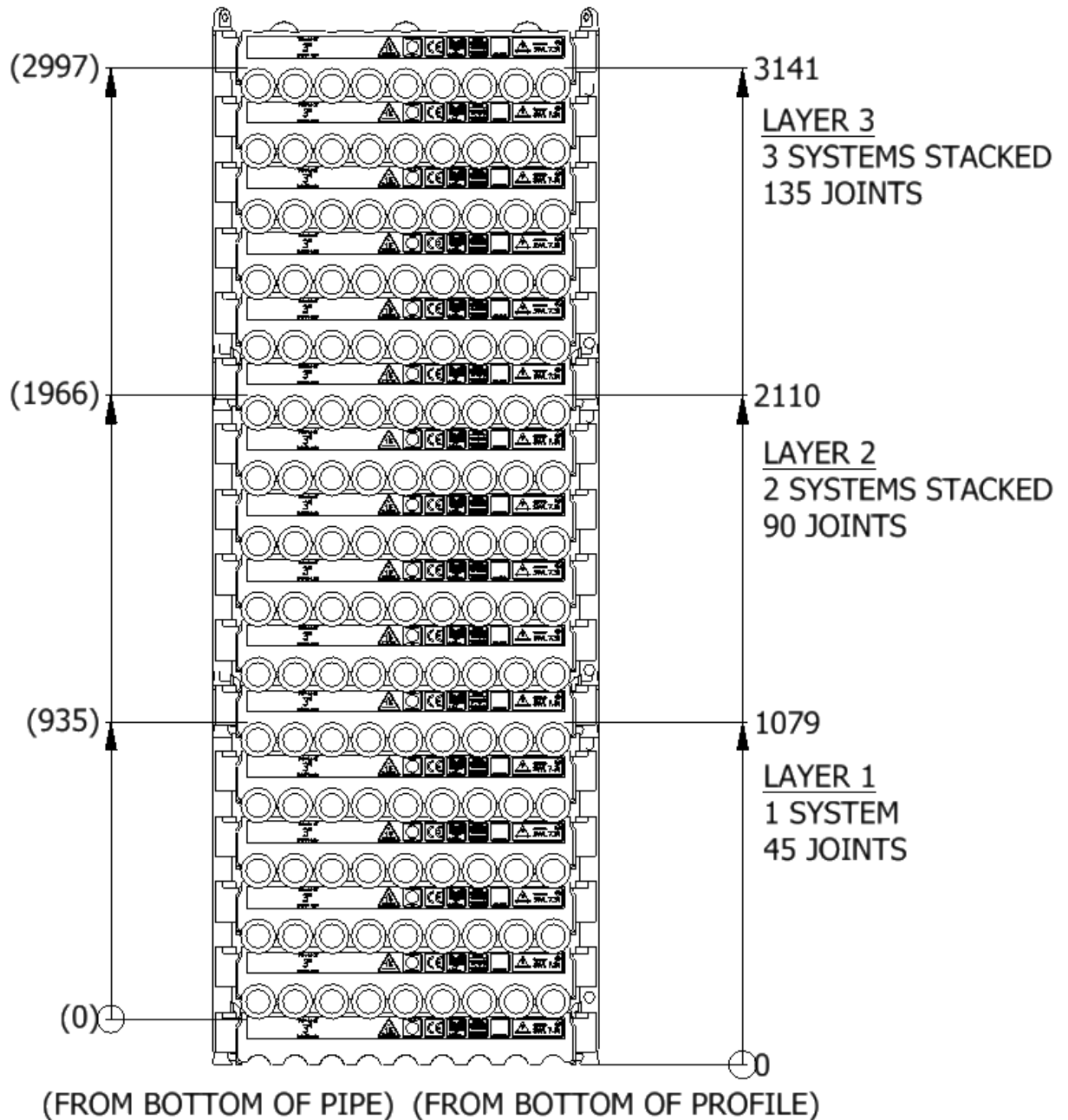

Spacing							
Status	w (width) n (number of rows)	S _w (system width)	k(constant)	y(info)	p(info)	T _w (total width)	f(constant)
Storages	$w = S_w + k \cdot (n - 1)$	1007	1113	0	106	$T_w = w + 2f$	106
Running on rig	$w = S_w + k \cdot (n - 1)$	1007	1153	40	146	$T_w = w + 2f$	106

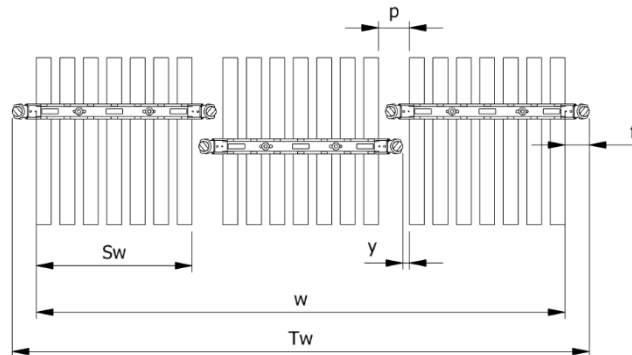

Topview of systems

Example:
Spacing of 3 systems

$$w = S_w + k \cdot (n - 1) = 1007 + 1153 \cdot (3 - 1) = 3445\text{mm}$$

$$T_w = w + 2f = 3445 + 2 \cdot 106 = 3525\text{mm}$$

The width “w” is the distance between the 2 outer most pipes
The total width “T_w” is between the 2 outer most Lifting Poles

Footprint

The figure below shows the footprint surface area of a TubeLock® system.
Each additional system stacked, will be added to the total footprint.

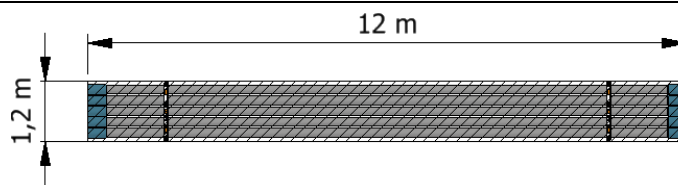

System Stacked	Footprint
1	5 kN/m ²
2	10 kN/m ²
3	15 kN/m ²