

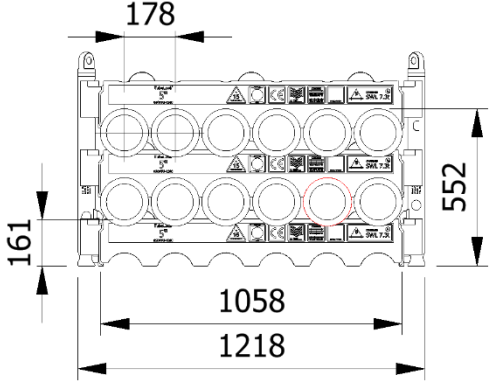

<h2>Data sheet</h2> <h3>0500TU-1200-2-C</h3>		
SWL	7.3 t	
Pipe OD	5"	
Maximum weight per pipe	593kg	
Pipe capacity per system	12	
M20 Bolt length	220mm	
Lifting pole	LP - C	
H-Profile	0500TU-1200	
TL weight per system	185 kg	
<p>CODES AND STANDARDS</p> <ul style="list-style-type: none"> • DNVGL-ST-0378 • NORSOK R-002 • LOLER 1998 Lifting operation and lifting equipment regulations • ILO Conversation No. 152 • CE declaration of conformity • Machinery Directive: MD2006/42/EC 		
<p>TEST</p> <ul style="list-style-type: none"> • Load Test 2X SWL on 5% per batch • NDT 100% of Primary per batch before and after test 		
<p>H-Profile</p> 		<p>Lifting Pole</p> 

Stacking

Systems Stacked	Height (mm)	Joints	Supported	Truck	Boat	Rig	Yard
1	552	12		X	X	X	X
2	1036	24		X	X	X	X
3	1520	36		X	X	X	X
4	2000	48		X	X	X	X
5	2488	60		(X)		X	X
6	2972	72	X			X	X

(x): Depending on Truck set-up and regulation

All sketch dimensions in mm

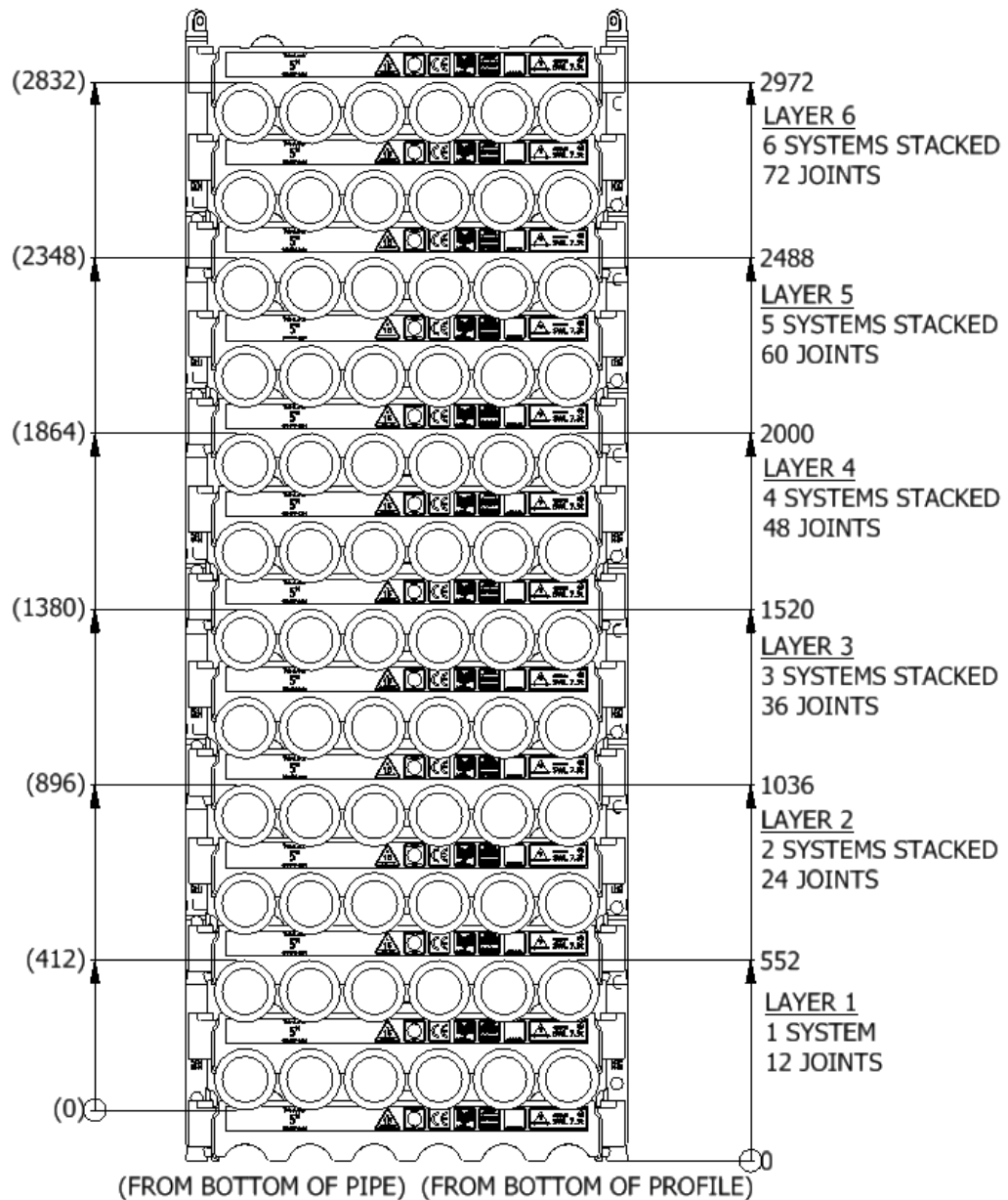

Spacing							
Status	w (width) n (number of rows)	S _w (system width)	k(constant)	y(info)	p(info)	T _w (total width)	f(constant)
Storages	$w = S_w + k \cdot (n - 1)$	1020	1120	0	100	$T_w = w + 2f$	100
Running on rig	$w = S_w + k \cdot (n - 1)$	1020	1160	40	140	$T_w = w + 2f$	100

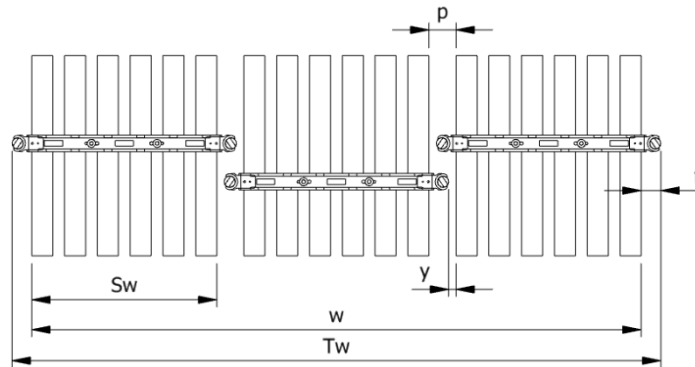

Example: Top view of Systems

Example:
Spacing of 3 systems

$$w = S_w + k \cdot (n - 1) = 1020 + 1120 \cdot (3 - 1) = 3260 \text{ mm}$$

$$T_w = w + 2f = 3260 + 2 \cdot 64 = 3460 \text{ mm}$$

The width “w” is the distance between the 2 outer most pipes
The total width “T_w” is between the 2 outer most Lifting Poles

Footprint

The figure below shows the footprint surface area of a TubeLock® system.
Each additional system stacked, will be added to the total footprint.

	System Stacked	Footprint
	1	5 kN/m ²
	2	10 kN/m ²
	3	15 kN/m ²
	4	20 kN/m ²
	5	25 kN/m ²
6	30 kN/m ²	