

## Data sheet 0550TU-1000-4-J

SWL	7.3 t
Pipe OD	5-1/2"
Maximum weight per pipe	351kg
Pipe capacity per system	20
M20 Bolt length	220mm
Lifting pole	LP - J
H-Profile	0550TU-1000
TL weight per system	267 kg

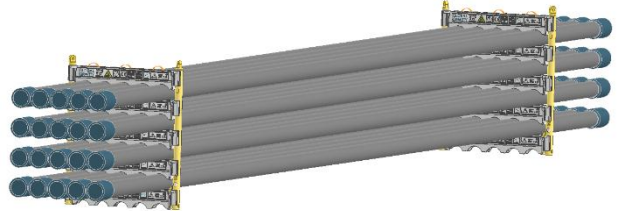

### CODES AND STANDARDS

- DNVGL-ST-0378
- NORSOK R-002
- LOLER 1998 Lifting operation and lifting equipment regulations
- ILO Conversation No. 152
- CE declaration of conformity
- Machinery Directive: MD2006/42/EC

### TEST

- Load Test 2X SWL on 5% per batch
- NDT 100% of Primary per batch before and after test

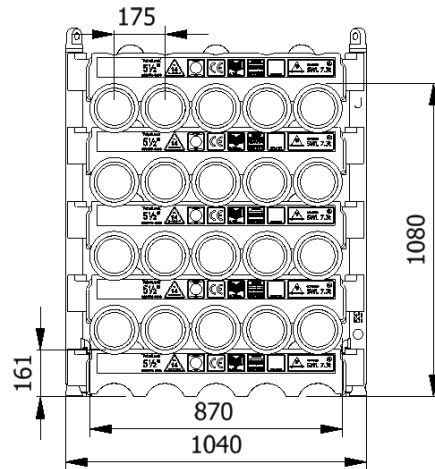

### H-Profile



### Lifting Pole



## Stacking

Sketch	Systems Stacked	Height (mm)	Joints	Support Required	Truck	Boat	Rig	Yard
A	1	1080	20		x	x	x	x
C	3	2100	40		(x)		x	x
D	4	3120	60	x			x	x

(x): Depending on Truck set-up and regulation

All sketch dimensions in mm

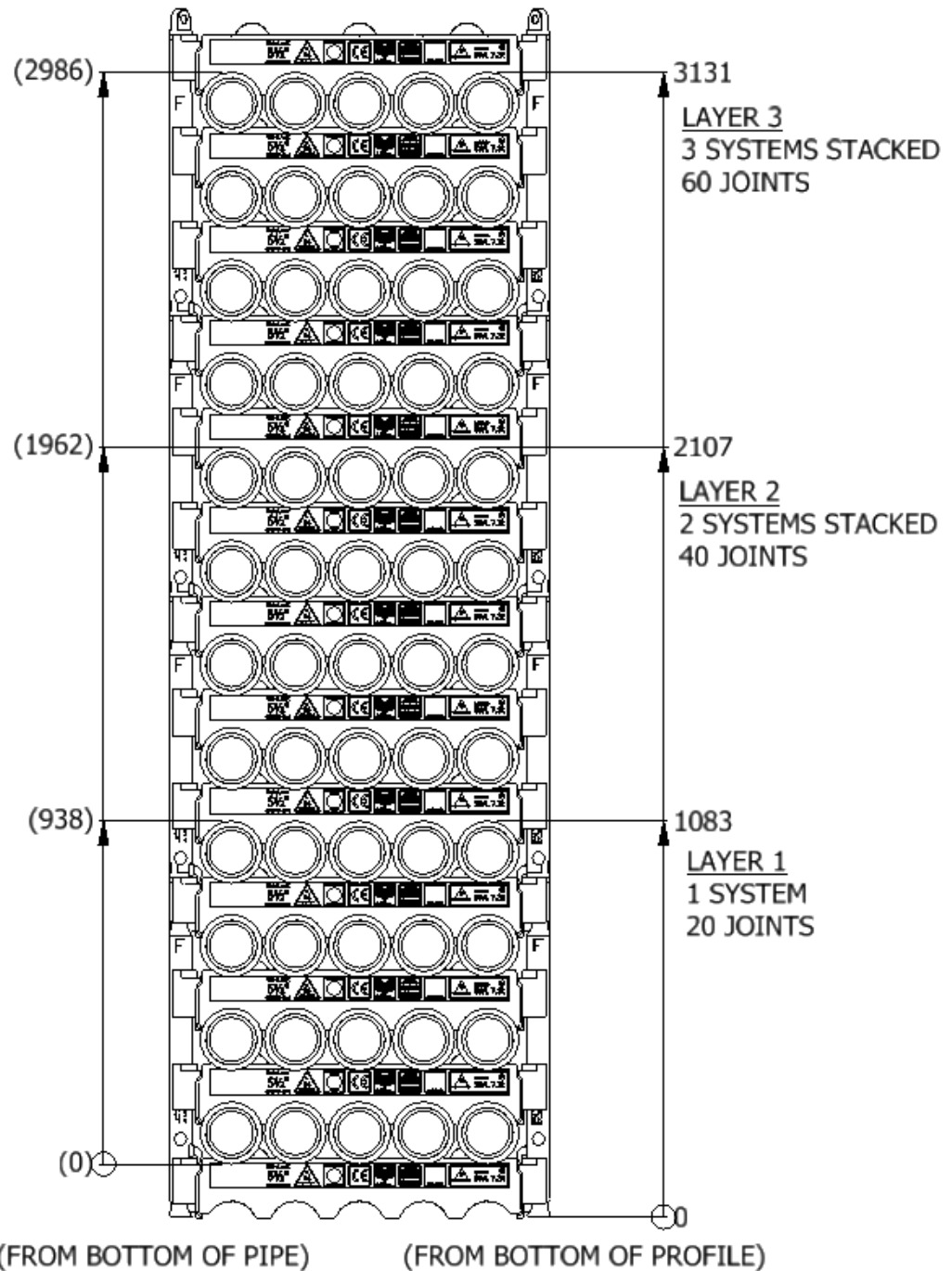

Spacing							
Status	w (width) n (number of rows)	S <sub>w</sub> (system width)	k(constant)	y(info)	p(info)	T <sub>w</sub> (total width)	f(constant)
Storages	w = S <sub>w</sub> + k · (n - 1)	840	940	0	100	T <sub>w</sub> = w + 2f	100
Running on rig	w = S <sub>w</sub> + k · (n - 1)	840	980	40	140	T <sub>w</sub> = w + 2f	100

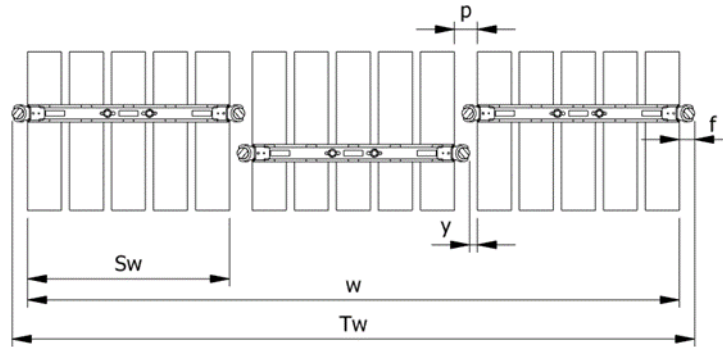

Example: Top view of Systems

Example:  
Spacing of 3 systems

$$w = S_w + k \cdot (n - 1) = 840 + 980 \cdot (3 - 1) = 2800\text{mm}$$

$$T_w = w + 2f = 2800 + 2 \cdot 100 = 3000\text{mm}$$

The width “w” is the distance between the 2 outer most pipes  
The total width “T<sub>w</sub>” is between the 2 outer most Lifting Poles

## Footprint

The figure below shows the footprint surface area of a TubeLock® system.  
Each additional system stacked, will be added to the total footprint

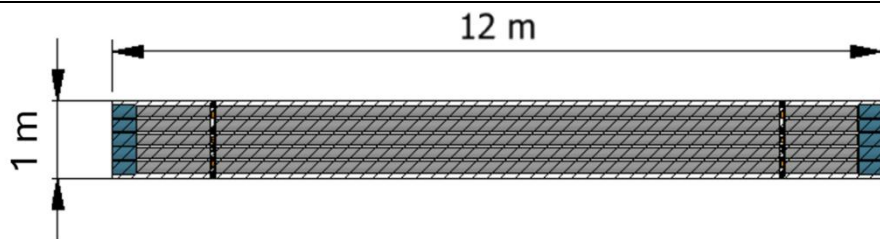

System Stacked	Footprint
1	6 kN/m <sup>2</sup>
2	12 kN/m <sup>2</sup>
3	18 kN/m <sup>2</sup>